



# TORNATECH

Project: \_\_\_\_\_

Customer: \_\_\_\_\_

Engineer: \_\_\_\_\_

Pump Manufacturer: \_\_\_\_\_

## Technical Data Submittal Document

### Model GPD

## Diesel Engine Driven Fire Pump Controller



### Contents:

Data Sheets  
Dimensional Data  
Wiring Schematics  
Field Connections

**Note:** The drawings included in this package are for controllers covered under our standard offering. Actual AS BUILT drawings may differ from what is shown in this package.



N.Y.C.  
APPROVED



November 2018



<b>Standard, Listings, Approvals and Certifications</b>	Built to NFPA 20 (latest edition)	
	Underwriters Laboratory (UL)	<ul style="list-style-type: none"> <li>• UL218 - Fire Pump Controllers</li> <li>• CSA C22.2 No. 14 Industrial Control Equipment</li> </ul>
	FM Global	Class 1321/1323
	New York City	Accepted for use in the City of New York by the Department of Buildings
	Seismic Certification	See page 5 for details
	<b>Optional</b>	
	<input type="checkbox"/> CE Mark	Various EN, IEC & CEE directives and standards
<b>Enclosure</b>	<b>Protection Rating</b>	
	<input type="checkbox"/> Standard: NEMA 2 (IP31)	
	<b>Optional</b>	
	<input type="checkbox"/> NEMA 12 <input type="checkbox"/> NEMA 3 <input type="checkbox"/> NEMA 3R <input type="checkbox"/> NEMA 4	<input type="checkbox"/> NEMA 4X-304 sst painted <input type="checkbox"/> NEMA 4X-304 sst brushed finish <input type="checkbox"/> NEMA 4X-316 sst painted <input type="checkbox"/> NEMA 4X-316 sst brushed finish
<b>Accessories</b>		<b>Paint Specifications</b>
<ul style="list-style-type: none"> <li>• Bottom entry gland plate</li> <li>• Lifting Lugs</li> <li>• Keylock handle</li> </ul>		<ul style="list-style-type: none"> <li>• Red RAL3002</li> <li>• Powder coating</li> <li>• Glossy textured finish</li> </ul>
<b>Ambient Temperature Rating</b>	<b>Standard</b>	
	<input type="checkbox"/> 4°C to 40°C / 39°F to 104°F	
	<b>Optional</b>	
	<input type="checkbox"/> 4°C to 55°C / 39°F to 131°F	
<b>General</b>	AC	<input type="checkbox"/> 120V / 1ph / 60hz <input type="checkbox"/> 208V to 240V / 1ph / 50-60hz
	DC	<input type="checkbox"/> 12VDC <input type="checkbox"/> 24VDC
	Grounding system	• Negative
	Battery chargers	<ul style="list-style-type: none"> <li>• Two independent fully automatic</li> <li>• 10A continuous charge</li> <li>• 500mA trickle charge</li> </ul>
<b>Electrical Reading</b>	<ul style="list-style-type: none"> <li>• Battery 1 &amp; Battery 2 voltage</li> <li>• Battery 1 &amp; Battery 2 charging amperage</li> <li>• Charging mode</li> </ul>	
<b>Pressure Reading</b>	<ul style="list-style-type: none"> <li>• Continuous system pressure display</li> <li>• Cut-in and cut-out pressure setting</li> </ul>	
<b>Pressure and Event Recorder</b>	<ul style="list-style-type: none"> <li>• Pressure readings with date stamp</li> <li>• Event recording with date stamp</li> <li>• Under regular maintained operation, events are stored in memory for the life of the controller.</li> <li>• Data viewable on operator interface display screen</li> <li>• Downloadable by USB port to external memory device</li> </ul>	





<b>Pressure sensing</b>	<ul style="list-style-type: none"> <li>• Pressure transducer and run test solenoid valve assembly for fresh water application</li> <li>• Pressure sensing connection 1/2" Female NPT</li> <li>• Drain connection 3/8"</li> <li>• Rated and calibrated for 0-500psi working pressure</li> <li>• Externally mounted with protective cover</li> </ul>
<b>Audible Alarm</b>	4" alarm bell - 85 dB at 10ft. (3m)
<b>Visual Indications</b>	<ul style="list-style-type: none"> <li>• Engine run</li> <li>• Main switch AUTO</li> <li>• Main switch in OFF</li> <li>• Main switch in HAND</li> <li>• Periodic test</li> <li>• Cranking Cycle</li> <li>• AC Power available</li> <li>• Pump room temperature (°F or °C)</li> </ul>
<b>Visual &amp; Audible Alarms</b>	<p>Visual only</p> <ul style="list-style-type: none"> <li>• Pump room trouble</li> <li>• Pump on demand</li> <li>• AC Failure</li> <li>• Charger 1 Failure</li> <li>• Charger 2 Failure</li> <li>• Weak battery 1</li> <li>• Weak battery 2</li> <li>• Battery 1 overvoltage</li> <li>• Battery 2 overvoltage</li> </ul> <p>Visual and Audible</p> <ul style="list-style-type: none"> <li>• Engine trouble</li> <li>• Controller trouble</li> <li>• Engine low oil pressure</li> <li>• Engine high temperature</li> <li>• Engine low temperature</li> <li>• Engine overspeed</li> <li>• DC Failure</li> <li>• Loss of continuity 1</li> <li>• Loss of continuity 2</li> <li>• High fuel level</li> <li>• Fuel tank leak</li> <li>• PLD low suction pressure</li> <li>• High raw water temperature</li> <li>• Low pump room temperature</li> <li>• Battery 1 Failure</li> <li>• Battery 2 Failure</li> <li>• Engine fail to start</li> <li>• Low fuel level</li> <li>• ECM fault</li> <li>• ECM SS in Alternate Position</li> <li>• Fuel injection malfunction</li> <li>• High pump room temperature</li> <li>• ECM warning</li> <li>• Weekly test cut-in not reached</li> <li>• Check weekly test solenoid</li> <li>• Pressure transducer fault</li> <li>• Invalid Cut-In</li> <li>• Service required</li> </ul>
<b>Remote Alarm Contacts</b>	<p>DPDT-8A-250V.AC</p> <ul style="list-style-type: none"> <li>• Engine run</li> <li>• Common controller trouble             <ul style="list-style-type: none"> <li>• Charger #1 &amp; Charger #2 failure</li> <li>• Pressure transducer fault</li> </ul> </li> <li>• Common engine trouble             <ul style="list-style-type: none"> <li>• High engine temperature</li> <li>• Fail to start</li> <li>• Fuel injection malfunction**</li> <li>• ECM selector switch in alternate position***</li> </ul> </li> <li>• Common pump room trouble (field re-assignable)*             <ul style="list-style-type: none"> <li>• Low fuel level</li> <li>• High fuel level</li> <li>• Fuel tank leak</li> <li>• Low pump room temperature</li> <li>• High pump room temperature</li> </ul> </li> <li>• H-O-A selector switch in OFF or HAND</li> <li>• Free (field programmable)*</li> <li>• Battery #1 &amp; battery #2 failure</li> <li>• DC failure</li> <li>• Loss of continuity (starter) #1 and/or #2</li> <li>• PLD low suction pressure</li> <li>• Overspeed</li> <li>• Fail when running</li> <li>• Low oil pressure</li> <li>• AC Failure</li> </ul>

\*Except if option C13 is ordered. Tornatech reserves the right to use any of these four alarm points for special specific application requirements

\*\*Applicable to electronic engines only.

\*\*\* Applicable to electronic engines only. Alarms when ECM selector switch on the engine is in alternate mode.



<b>Terminals for Field Connections for External Devices</b>	<ul style="list-style-type: none"> <li>• Low fuel level</li> <li>• Remote AUTOMATIC start</li> <li>• Deluge valve start (re-assignable)</li> <li>• Fuel tank leak (re-assignable)</li> <li>• High fuel level (re-assignable)</li> </ul>		
<b>ViZiTouch V2 Operator Interface</b>	<ul style="list-style-type: none"> <li>• Embedded microcomputer with software PLC logic</li> <li>• 7.0" color touch screen (HMI technology)</li> <li>• Upgradable software</li> <li>• Multi-language</li> </ul>		
<b>Operation</b>	<b>Selector Switch</b>	<ul style="list-style-type: none"> <li>• Hand-Off-Auto</li> <li>• Behind lockable and breakable cover</li> </ul>	
	<b>Automatic Start</b>	<ul style="list-style-type: none"> <li>• Start on pressure drop</li> <li>• Remote start signal from automatic device</li> </ul>	
	<b>Manual Start</b>	<ul style="list-style-type: none"> <li>• Crank 1 and Crank 2 start pushbuttons</li> <li>• Run test pushbutton</li> <li>• Deluge valve start</li> <li>• Remote start from manual device</li> </ul>	
	<b>Crank Cycle</b>	<ul style="list-style-type: none"> <li>• 6 consecutive cycle attempts               <ul style="list-style-type: none"> <li>• 3 X 15s crank from battery 1 or 2 alternatively</li> <li>• 15s rest in between each crank attempt</li> </ul> </li> </ul>	
	<b>Stopping</b>	<ul style="list-style-type: none"> <li>• Manual with Stop pushbutton</li> <li>• Automatic after expiration of minimum run timer ****</li> </ul>	
	<b>Timers</b>	<b>Field Adjustable &amp; Visual Countdown</b>	<ul style="list-style-type: none"> <li>• Minimum run timer ****(off delay)</li> <li>• Sequential start timer (on delay)</li> <li>• Periodic test timer</li> </ul>
	<b>Actuation</b>	<b>Visual Indication</b>	<ul style="list-style-type: none"> <li>• Pressure</li> <li>• Non-pressure</li> </ul>
	<b>Mode</b>		<ul style="list-style-type: none"> <li>• Automatic</li> <li>• Non-automatic</li> </ul>
<b>Communication Protocol Capability</b>	<ul style="list-style-type: none"> <li>• Protocol: Modbus</li> <li>• Connection type: Shielded female connector RJ45</li> <li>• Frame Format: TCP/IP</li> <li>• Addresses: See bulletin MOD-GPD</li> </ul>		

<b>Alarm and shutdown schedule</b>		Automatic Start	Manual or Remote Start	Run Test or Periodic Test
	High Coolant	Alarm only	Alarm only	Shutdown
	Low Oil Pressure	Alarm only	Alarm only	Shutdown
	Overspeed	Shutdown	Shutdown	Shutdown

	<b>Wall Mount</b>		<b>Floor Mount</b>	
Starting Voltage	Approx. shipping dimensions in inches (mm)	Approx. Shipping Weight in Lbs (kg)	Approx. shipping dimensions in inches (mm)	Approx. Shipping Weight in Lbs (kg)
12V.DC	32" l x 29" w x 16" h (813 x 737 x 407 )	85 (39)	32" l x 29" w x 26" h (813 x 737 x 661)	115 (52)
24V.DC				

\*\*\*\* Automatic shutdown shall be approved by the AHJ.



<b>Seismic Certification</b>	Seismic Certification Company	TRU Compliance, LLC A Tobalski Watkins Affiliate					TWEI Project No.: 15014				
	Mounting details	Rigid wall mounting									
	Seismic Information	Building Code	Test Criteria	Seismic Parameters	<b>S<sub>DS</sub></b>	<b>z/h</b>	<b>I<sub>P</sub></b>	<b>A<sub>FLX-H</sub></b>	<b>A<sub>RIG-H</sub></b>	<b>A<sub>FLX-V</sub></b>	<b>A<sub>RIG-V</sub></b>
	IBC 2015, CBC 2016	ICC-ES AC156	ASCE 7-10 Chapter 13	2.0	1.0	1.5	3.20	2.40	1.33	0.53	
				3.2	0.0	1.5	3.20	1.28	2.13	0.85	

RRS for Nonstructural Components Testing

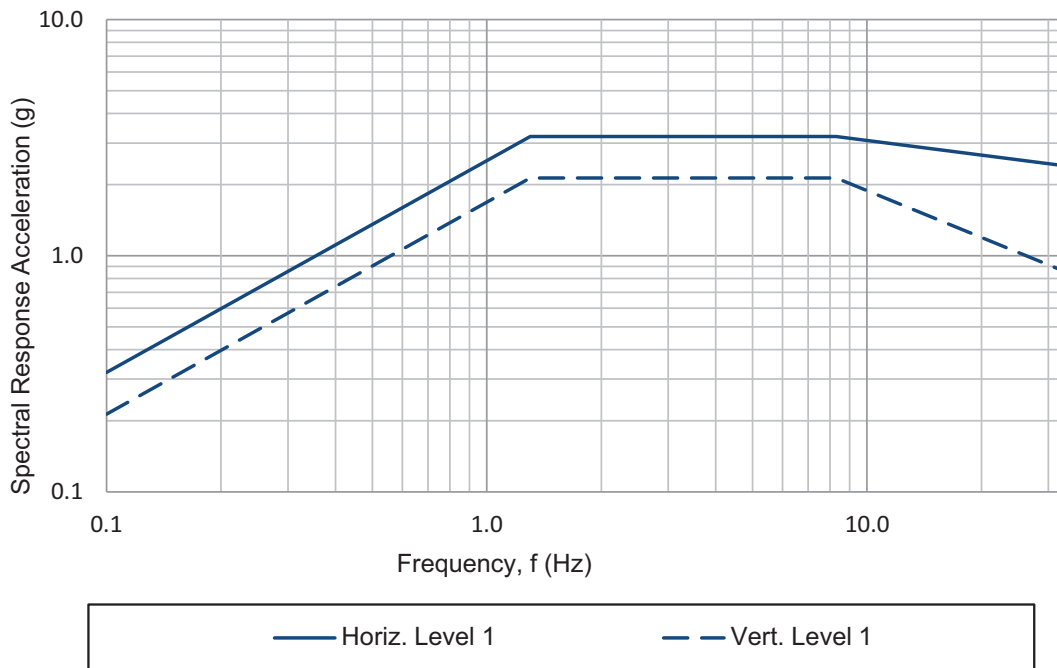

**Notes:**

- Components are tested in accordance with ICC-ES AC156, IBC 2015 & CBC 2016.
- OSHPD Special Seismic Certification Preapproval (OSP)



<input type="checkbox"/>	A1	Periodic test alarm contact (DPDT)
<input type="checkbox"/>	A2	Overspeed alarm contact (DPDT)
<input type="checkbox"/>	A3	Low oil pressure alarm contact (DPDT)
<input type="checkbox"/>	A4	High coolant temperature alarm contact (DPDT)
<input type="checkbox"/>	A5	Failure to start alarm contacts alarm contact (DPDT)
<input type="checkbox"/>	A6	Battery 1 & 2 failure alarm contact (2 x DPDT)
<input type="checkbox"/>	A7	Charger 1 & 2 failure alarm contact (2 x DPDT)
<input type="checkbox"/>	A8	AC failure alarm contact (DPDT)
<input type="checkbox"/>	A9	System overpressure alarm contact (For engines with PLD) (DPDT)
<input type="checkbox"/>	A11	Extra controller trouble alarm contact (DPDT)
<input type="checkbox"/>	A12	Extra engine trouble alarm contact (DPDT)
<input type="checkbox"/>	Ax	Additional engine alarm contact (DPDT) (specify function)
<input type="checkbox"/>	B1	Low fuel level alarm contact (DPDT)
<input type="checkbox"/>	B2	Water reservoir level low alarm contact (DPDT)
<input type="checkbox"/>	B3	Water reservoir empty alarm contact (DPDT)
<input type="checkbox"/>	B4	Low pump room temperature alarm contact (DPDT)
<input type="checkbox"/>	B5	High fuel level alarm contact (DPDT)
<input type="checkbox"/>	B6	Low system (discharge) pressure alarm contact (DPDT)
<input type="checkbox"/>	B7	Low suction pressure alarm contact (DPDT)
<input type="checkbox"/>	B8	Pump on demand alarm contact (DPDT)
<input type="checkbox"/>	B9	Fuel tank leak alarm contact (DPDT)
<input type="checkbox"/>	B10	Main relief valve open alarm contact (DPDT)
<input type="checkbox"/>	B11	Flow meter loop valve open alarm contact (DPDT)
<input type="checkbox"/>	B12	Water reservoir level high alarm contact (DPDT)
<input type="checkbox"/>	B13	High pump room temperature alarm contact (DPDT)
<input type="checkbox"/>	Bx	Additional pump room alarm contact (DPDT) (specify function)
<input type="checkbox"/>	C5	CE Mark with factory certificate
<input type="checkbox"/>	C6	Nickel – cadmium battery chargers (Battery data sheet required)
<input type="checkbox"/>	C7	Engine block heater circuit - 3KW max (same voltage as battery charger primary)

<input type="checkbox"/>	C7A	Engine block heater circuit - 6KW max (same voltage as battery charger primary) Confirm power rating of block heater
<input type="checkbox"/>	C9	Non pressure actuated controller w/o pressure transducer and run test solenoid valve
<input type="checkbox"/>	C13	Louver activation circuit (battery power specific)
<input type="checkbox"/>	C14	Delayed automatic start on AC power failure (factory set at 15 minutes)
<input type="checkbox"/>	C15	Low zone pump control function
<input type="checkbox"/>	C16	Middle zone pump control function
<input type="checkbox"/>	C17	High zone pump control function
<input type="checkbox"/>	C19	Lockout/interlock circuit from equipment installed inside the pump room
<input type="checkbox"/>	D4	Pressure transducer and run test solenoid valve for fresh water rated for 0-500psi (for factory calibration purposes only)
<input type="checkbox"/>	D6	Pressure transducer and run test solenoid valve for sea water rated for 0-500PSI
<input type="checkbox"/>	D7A	Low fuel level float switch supplied as separate item (1-1/4")
<input type="checkbox"/>	D7B	Low fuel level float switch supplied as separate item (1-1/2")
<input type="checkbox"/>	D8A	High fuel level float switch supplied as separate item (1-1/4")
<input type="checkbox"/>	D8B	High fuel level float switch supplied as separate item (1-1/2")
<input type="checkbox"/>	D9A	Anti-condensation heater & thermostat
<input type="checkbox"/>	D9B	Anti-condensation heater & humidistat
<input type="checkbox"/>	D9C	Anti-condensation heater & thermostat & humidistat
<input type="checkbox"/>	D11	Low suction pressure transducer for fresh water rated at 0-300PSI with visual indication and alarm contact
<input type="checkbox"/>	D11A	Low suction pressure transducer for sea water rated at 0-300PSI with visual indication and alarm contact
<input type="checkbox"/>	D12	Tropicalization
<input type="checkbox"/>	D25	Mounting stand
<input type="checkbox"/>	D25A	Mounting stand SST- 304 painted
<input type="checkbox"/>	D25B	Mounting stand SST- 304 brushed finish
<input type="checkbox"/>	D25C	Mounting stand SST- 316 painted
<input type="checkbox"/>	D25D	Mounting stand SST- 316 brushed finish
<input type="checkbox"/>	D26	Combined low and high fuel level float switch (1-1/4")

Note: Options chosen from this page are not electrically represented on the wiring schematics in this submittal package.



<input type="checkbox"/>	D26A	Combined low and high fuel level float switch (1-1/2")
<input type="checkbox"/>	D27	Fuel level probe (2") Level indication
<input type="checkbox"/>	D28A	Field programmable I/O board - 5 Input / 5 output
<input type="checkbox"/>	D30	Redundant pressure transducer for fresh water rated for 0-500PSI
<input type="checkbox"/>	D31	Redundant pressure transducer for sea water rated for 0-500PSI
<input type="checkbox"/>	D32	Modbus with RTU frame format and RS485 connection

<input type="checkbox"/>	L01	Other language and English (bilingual)
<input type="checkbox"/>	L02	French
<input type="checkbox"/>	L03	Spanish
<input type="checkbox"/>	L04	German
<input type="checkbox"/>	L05	Italian
<input type="checkbox"/>	L06	Polish
<input type="checkbox"/>	L07	Romanian
<input type="checkbox"/>	L08	Hungarian
<input type="checkbox"/>	L09	Slovak
<input type="checkbox"/>	L10	Croatian
<input type="checkbox"/>	L11	Czech
<input type="checkbox"/>	L12	Portuguese
<input type="checkbox"/>	L13	Dutch
<input type="checkbox"/>	L14	Russian
<input type="checkbox"/>	L15	Turkish
<input type="checkbox"/>	L16	Swedish
<input type="checkbox"/>	L17	Bulgarian
<input type="checkbox"/>	L18	Thai
<input type="checkbox"/>	L19	Indonesian
<input type="checkbox"/>	L20	Slovenian
<input type="checkbox"/>	L21	Danish
<input type="checkbox"/>	L22	Greek
<input type="checkbox"/>	L23	Arabic
<input type="checkbox"/>	L24	Hebrew
<input type="checkbox"/>	L25	Chinese

Additional Options:

\_\_\_\_\_

\_\_\_\_\_

\_\_\_\_\_

\_\_\_\_\_

\_\_\_\_\_

Note: Options chosen from this page are not electrically represented on the wiring schematics in this submittal package.

### ViZiTouch V2 Operator Interface

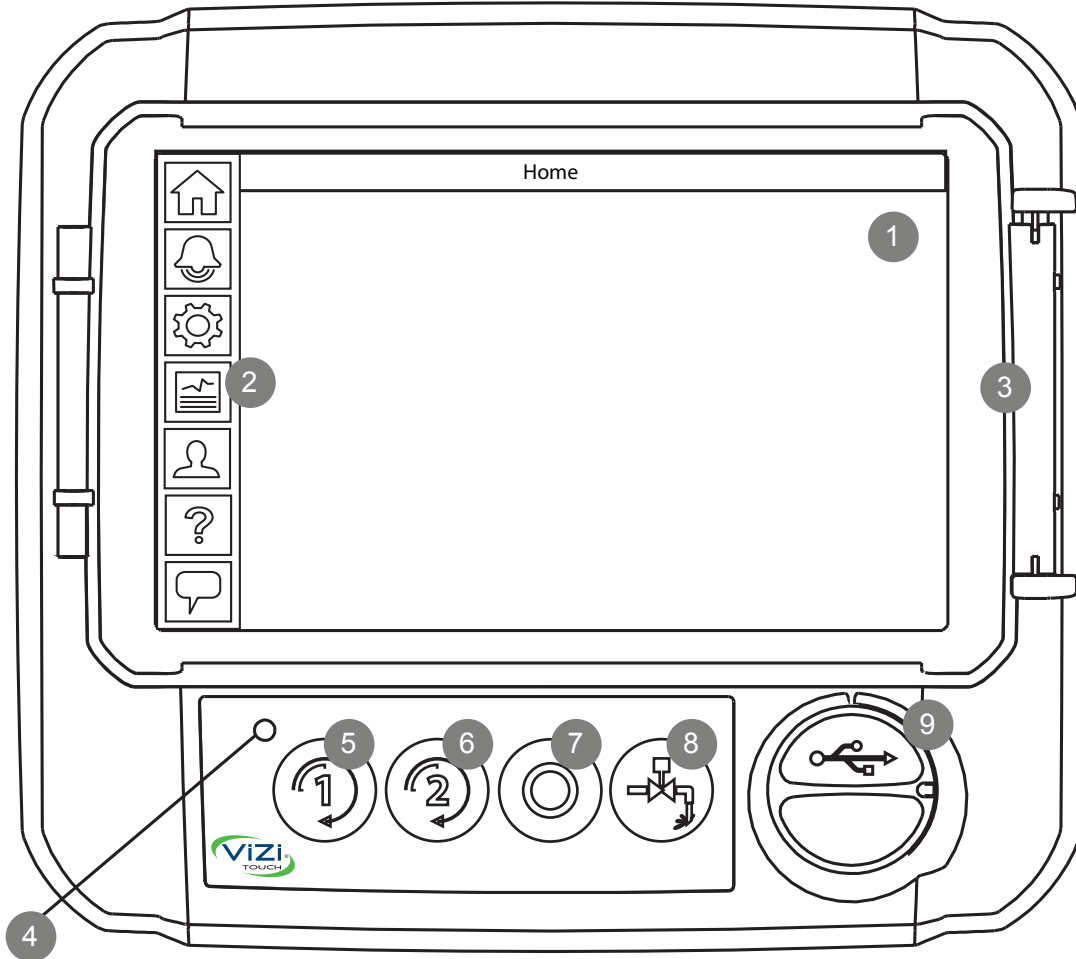

- |                        |                          |
|------------------------|--------------------------|
| 1 - Color touch screen | 3 - Screen protector     |
| 2 - Onscreen menu      | 4 - Power LED (3 colors) |
| • HOME page            | 5 - CRANK 1 button       |
| • ALARM page           | 6 - CRANK 2 button       |
| • CONFIGURATION page   | 7 - STOP button          |
| • HISTORY page         | 8 - RUN TEST button      |
| • SERVICE page         | 9 - USB port             |
| • MANUAL page          |                          |
| • LANGUAGES page       |                          |

# Diesel Engine Fire Pump Controller

12Vdc or 24Vdc Negative Ground

Model: GPD

## Dimensions

Built to the latest edition of the NFPA 20 standard

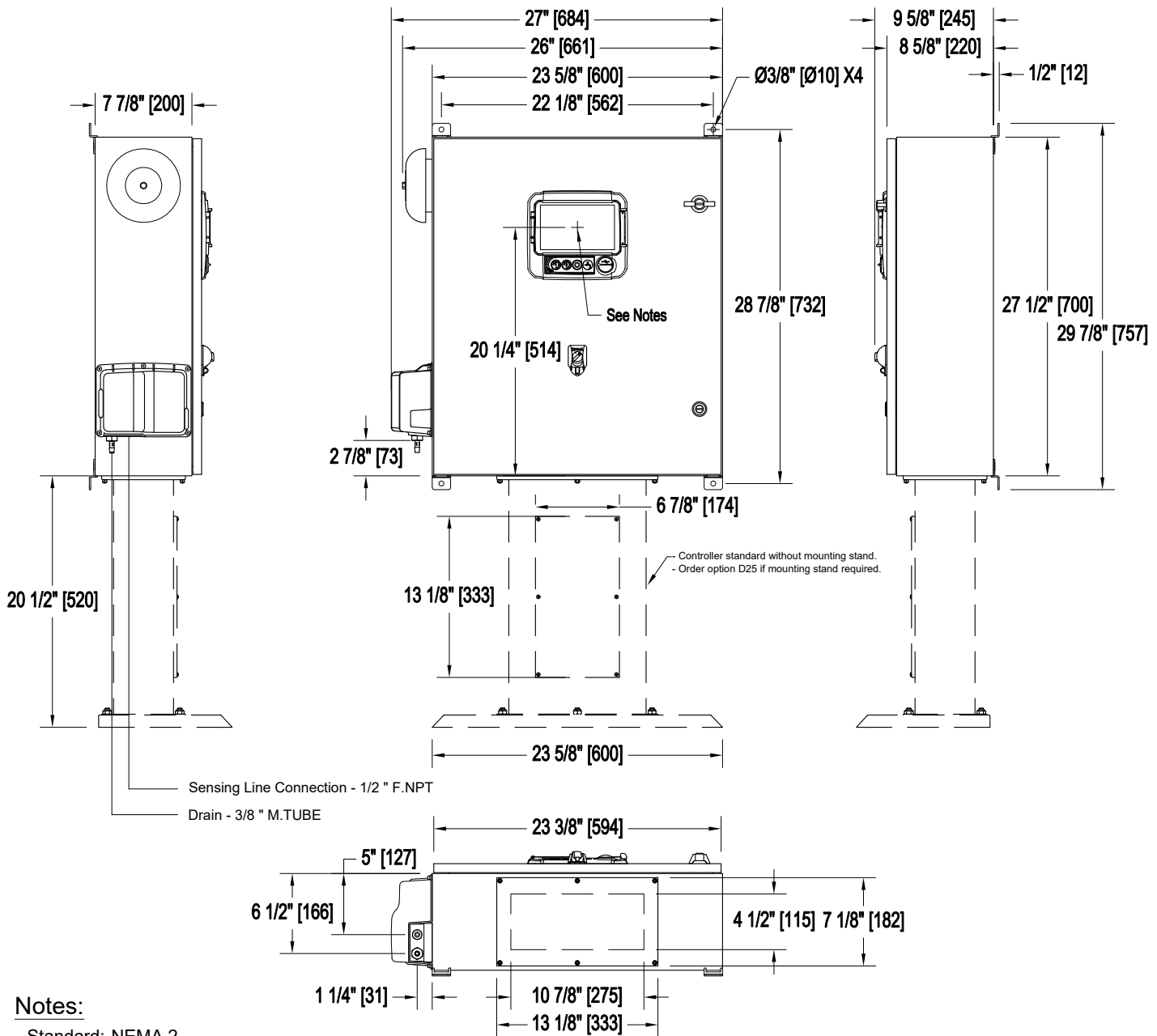

### Notes:

- Standard: NEMA 2
- Standard paint : textured red RAL 3002.
- All dimensions are in inches [millimeters].
- Center of ViZiTouch screen: 20-1/4" [514] from bottom (no feet).
- Bottom conduit entrance through removable gland plate recommended.
- Use watertight conduit and connector only.
- Protect equipment against drilling chips.
- Door swing equal to door width.
- Seismic mounting to be rigid wall only.

Drawing for information only.  
 Manufacturer reserves the right to modify this drawing without notice.  
 Contact manufacturer for "As Built" drawing.

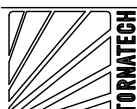
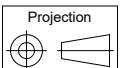

REV.	DESCRIPTION	DD/MM/YY	Drawing number
1.	Revised logo	18/06/18	GPD-DI700 /E
0.	First issue	18/11/16	

# Diesel Engine Fire Pump Controller

## 12VDC or 24VDC Negative Ground

Model: GPD

### Wiring schematic

Built to the latest edition of the NFPA 20 standard

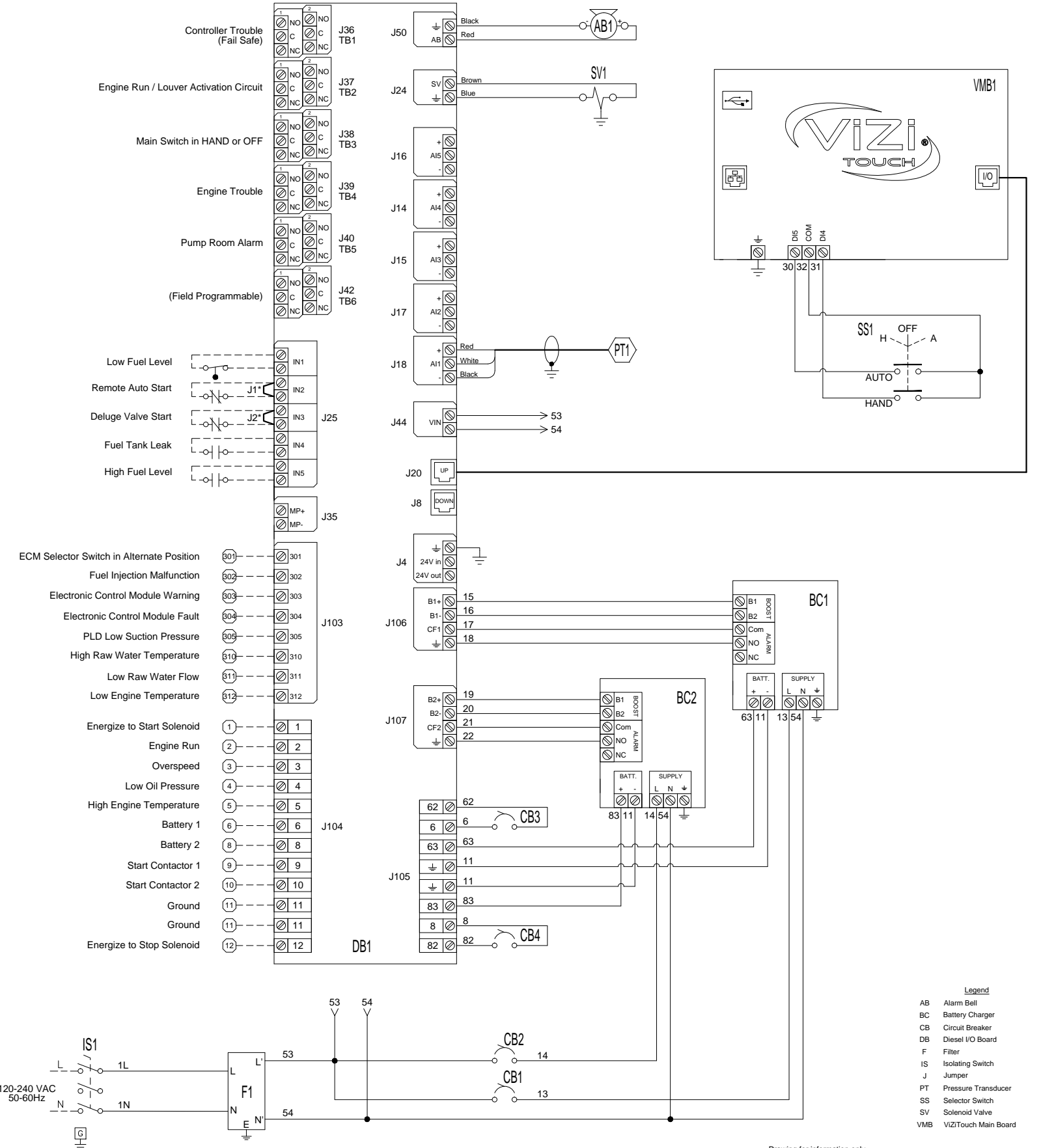

\* Remove jumper to use this feature

Drawing for information only. Manufacturer reserves the right to modify this drawing without notice. Contact manufacturer for "As Built" drawing.

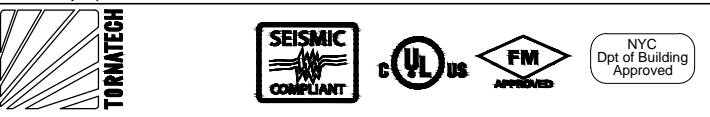

REV.	DESCRIPTION	DD/MM/YY	Drawing number
2	Revised logo	18/06/18	GPD-WS700 /E
1	Corrected SS1 inputs	16/01/17	
0	First issue	10/11/16	

# Diesel Engine Fire Pump Controller

## 12VDC or 24VDC Negative Ground

### Layout

Model:GPD

Built to the latest edition of the NFPA 20 standard

Designation	Description
BC1-BC2	Battery Charger #1 and #2
CB1-2	Magnetic Breaker 1 Pole 10 A
CB3-4	Magnetic Breaker 1 Pole 16 A
DB1	I/O Diesel Board
F1	Filter
IS1	Isolating Switch
SS1	Lockable 3 Position Selector Switch
VMB1	ViZiTouch Main Board

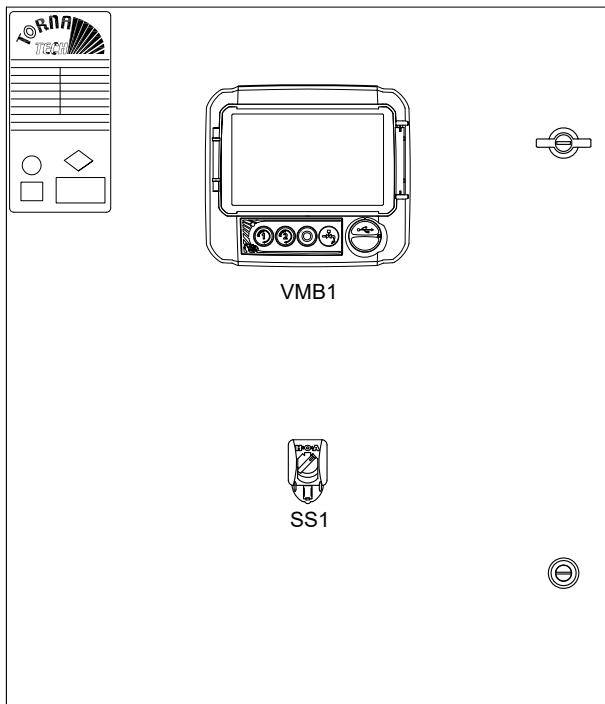

Front Door Layout

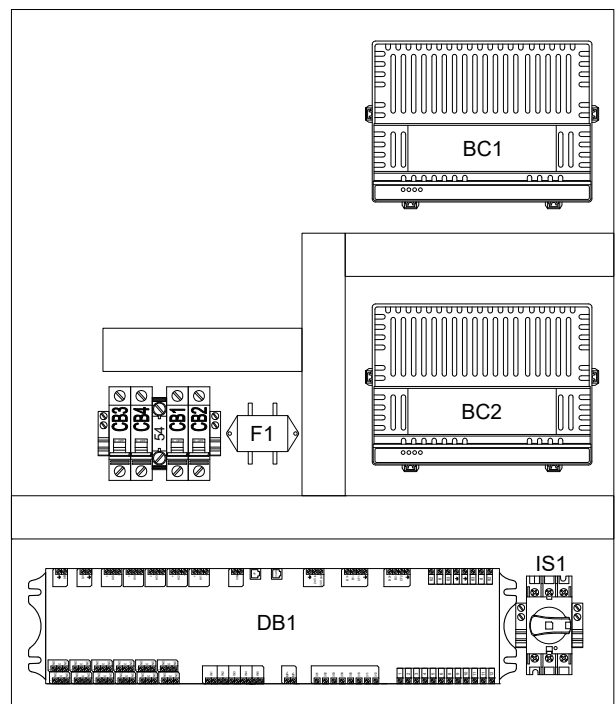

Internal Layout



REV.	DESCRIPTION	DD/MM/YY	Drawing number
1	Revised logo	18/06/18	GPD-LY700 /E
0	First issue	21/11/16	

# Diesel Engine Fire Pump Controller

## 12VDC or 24VDC Negative Ground

# Model: GPD

### Terminal Diagram

Built to the latest edition of the NFPA 20 standard

#### Power Supply

Terminals Wire Size:  
14 - 6 AWG  
3.9 Nm

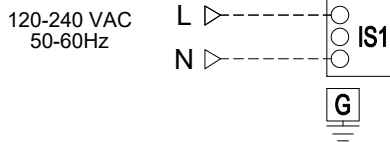

#### Engine Connections (DB1)

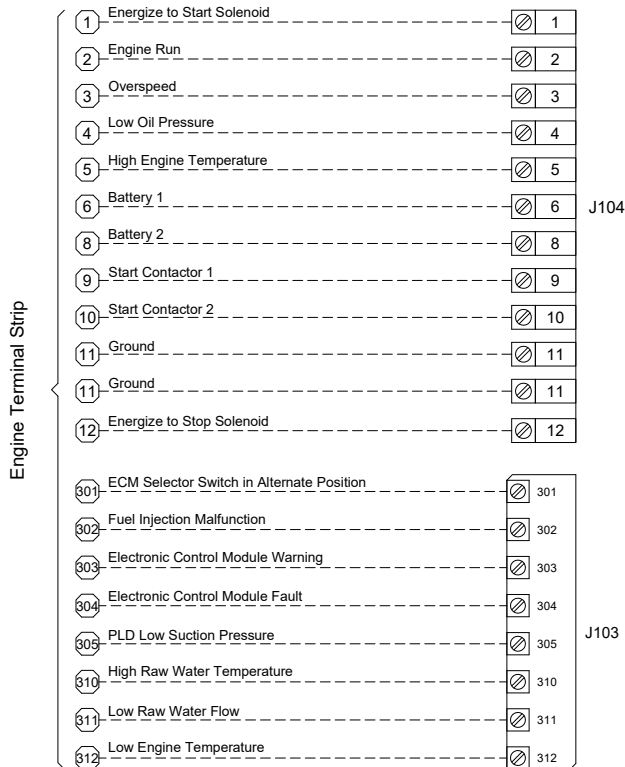

#### Field Connections (DB1)

Terminals Wire Size:  
24 - 12 AWG  
0.5 Nm

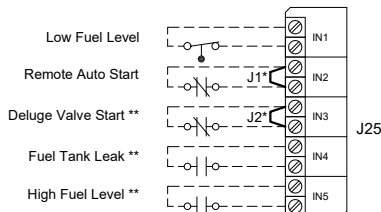

#### Network Connection (VMB1)

Shielded Female Connector RJ45

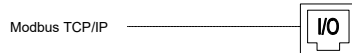

#### Remote Alarm Terminals (DB1)

Terminals Wire Size:  
24 - 12 AWG  
0.5 Nm

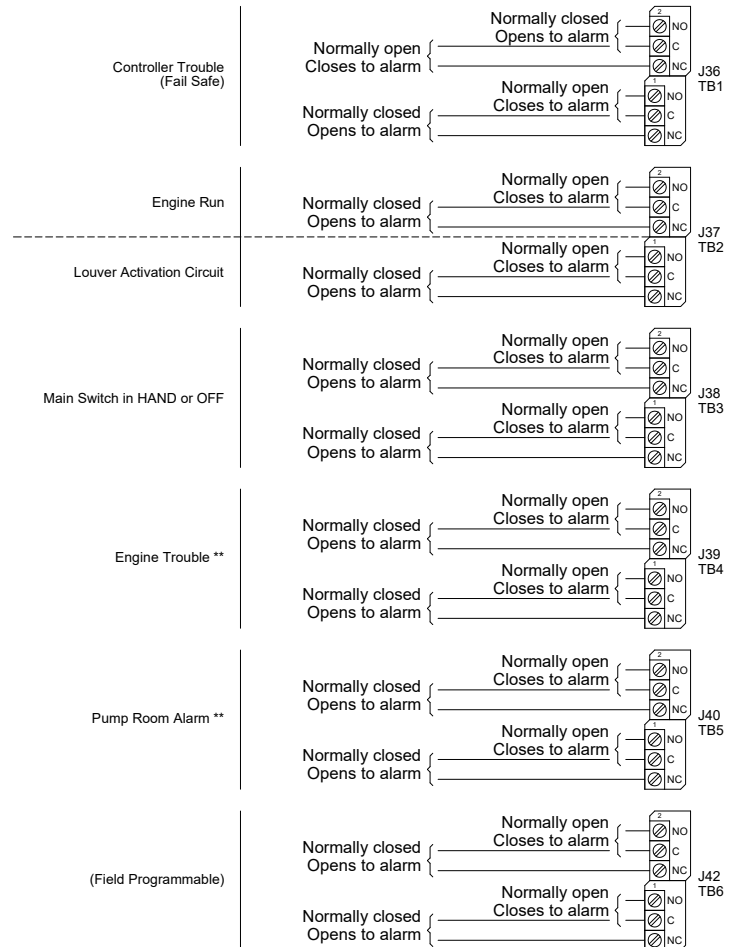

All wiring between the controller and diesel engine shall be stranded (NFPA20)

Wiring between controller and engine (terminals 301, 302, 303, 304, 305, 310, 311, 312, 2, 3, 4, 5) must be #14AWG as minimum.

Wiring between controller and engine (terminals 12 [rated at 10A or 22A for 20 seconds] 1, 9, 10 [rated at 10A]) must be stranded #10AWG as minimum.

Wiring between controller and engine (terminals 6, 8, 11 [rated at 30A]) must be stranded and sized according to distance.

Drawing for information only.  
Manufacturer reserves the right to modify this drawing without notice.  
Contact manufacturer for "As Built" drawing.

\* Remove jumper to use this feature  
\*\* Re-assignable



REV.	DESCRIPTION	DD/MM/YY	Drawing number
1	Revised logo	18/06/18	GPD-TD700 /E
0	First issue	10/11/16	

# Diesel Engine Fire Pump Controller

12VDC or 24VDC Negative Ground

Model: GPD

## Louver Connection

Built to the latest edition of the NFPA 20 standard

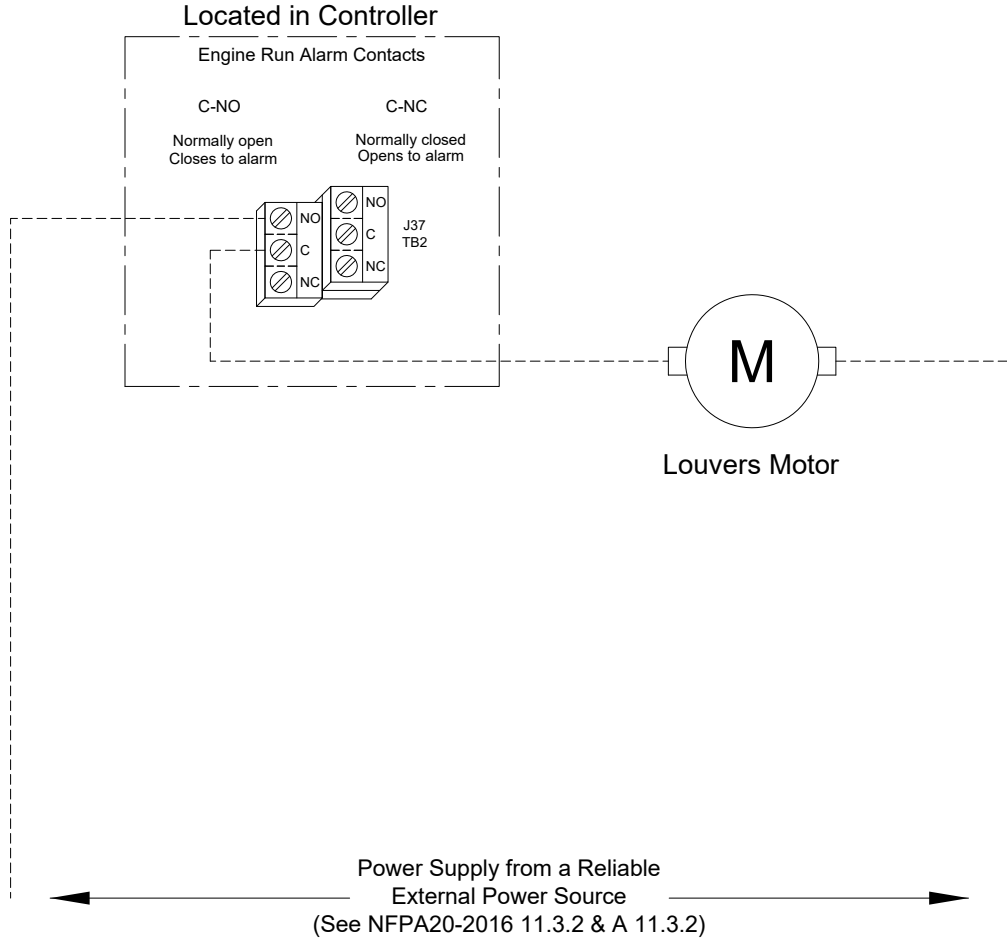

REV.	DESCRIPTION	DD/MM/YY	Drawing number
1	Revised logo	18/06/18	GPD-TD701 /E
0	First issue	10/11/16	